

PHANTOM IP44 / IP65



INCASSO WALL WASHER DI PICCOLE DIMENSIONI.

Phantom IP44/IP65 è un apparecchio da esterni, incasso a scomparsa totale per l'installazione a parete e soffitto di cartongesso o laterizio.

La soluzione più corretta per introdurre la luce negli ambienti esterni, grazie al materiale in Coral WaterOut®, con l'obiettivo di raccontare scenari sempre diversi. L'illuminazione definisce gli spazi, li determina, li valorizza, stagliandosi, netta, attraverso le superfici.

SMALL WALL WASHER RECESSED FITTING.

Phantom IP44/IP65 is a totally disappearing outdoor recessed luminaire, installable on plasterboard or brick walls and ceilings.

It is the best solution to spread light on external environments thanks to the material it is made of, Coral WaterOut®, narrating ever different landscapes. Its lighting defines, determines and enhances spaces, standing out, sharply, through surfaces.

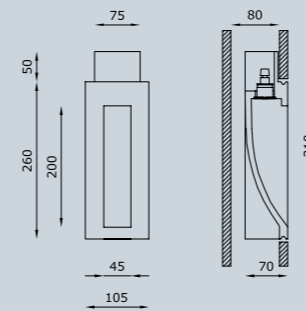

Outdoor



TECHNICAL FEATURES

Code	6489.CW	6487.CW
Type	Wall-washer 	Wall-washer
Material	CW: Coral WaterOut® waterproof	CW: Coral WaterOut® waterproof
Weight	1.4 Kg	1.4 Kg
Mounting	Wall and ceiling recessed	Wall and ceiling recessed
IP rating	IP44	IP65
Insulation class	III	III
Control gear	Constant current electronic driver (not included)	Constant current electronic driver (not included)
Cut out for plasterboard	115 x 270 mm	115 x 270 mm
Lamp type	LED Vf: 3 VDC	LED Vf: 3 VDC
Lamp wattage	1W - 350 mA 2W - 500 mA	1W - 350 mA 2W - 500 mA
Luminous efficacy	75 lm - 3000K 350 mA 170 lm - 3000K 500 mA	75 lm - 3000K 350 mA 170 lm - 3000K 500 mA
Light distribution	Narrow beam 14°	Narrow beam 14°
Fitting	-	-
Light colour	White 3000K White 2700K (on request)	White 3000K White 2700K (on request)
Light hole	45 x 200 mm	45 x 200 mm
Voltage connection	By driver (optional)	By driver (optional)
CRI	>90	>90
Emergency	-	-
Energy efficiency class	A++	A++
Note	On request available dimmable PUSH or DALI, remote installation.	On request available dimmable PUSH or DALI, remote installation.

OPTIONAL ACCESSORIES

product code	optional code	description	info
6489.CW / 6487.CW	H8350	Constant current electronic driver	Suitable for n°1 code 6489.CW / 6487.CW - 350 mA (IP40)
	H8500.B	Constant current electronic driver. Remote installation	Suitable for n°5 code 6489.CW / 6487.CW - 500 mA (IP40)
	H8500.C	Constant current electronic driver. Remote installation	Suitable for n°2 code 6489.CW / 6487.CW - 500 mA (IP40)
	BR6489LT / BR6487LT	Brick box	Dimensions L: 340 mm; W: 115 mm; D: 80 mm (instructions on page 502)