



**ATTENZIONE:**

Tutte le operazioni di montaggio, manutenzione e sostituzione lampadine, vanno eseguite assicurandosi che la rete di alimentazione sia disinserita.

**ATTENTION:**

Toutes les opérations de montage, entretien et remplacement des ampoules ne doivent être effectuées qu'après avoir coupé le courant.

**CUIDADO:**

Todas las operaciones de montaje, manutención y substitución de lámparas tienen que realizarse después de comprobar que la red de suministro está desconectada.

**ACHTUNG:**

Montage, Wartung und Lampenwechsel dürfen nur nach Unterbrechung des Netzanschlusses durchgeführt werden.

**WARNING:**

when carrying out all assembly, maintenance and bulbs replacement operations, make sure that the supply is OFF.

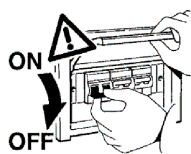

**ATTENZIONE:**

La sicurezza dell'apparecchio è garantita con l'uso appropriato delle istruzioni. Pertanto è necessario conservarle.

**ATTENTION:**

La sûreté de l'appareil est garantie avec l'utilisation appropriée des instructions. Il est donc nécessaire de les garder.

**CUIDADO:**

La seguridad del aparato está garantizada se si hace el uso apropiado de las siguientes instrucciones. Por lo tanto es necesario conservarlas.

**ACHTUNG:**

Die Sicherheit des Gerätes ist nur garantiert, wenn die folgenden Vorschriften eingehalten werden. Es ist daher notwendig diese aufzubewahren.

**WARNING:**

The safety of the fitting is guaranteed by the correct use of the instructions. It is therefore necessary to keep them.

## UNDERSCORE

MONTAGGIO A TERRA

Ground mounted

Bodenmontage

### 1751.DC

6W 24V

LED White 3000 K

IP65

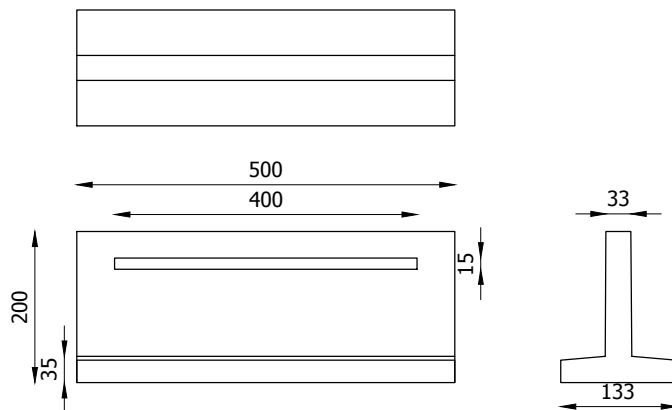

Per difetti riscontrati indicare il numero di controllo.

En cas de défauts mentionner le numéro de contrôle.

En caso de defectos hacer mención del número de control.

Für eventuell festgestellte Mängel bitte die Kontrollnummer angeben.

For any manufacturing defect refer to the check number.

Controllo  
Contrôle  
Control  
Kontrolle  
Control

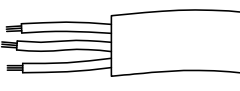
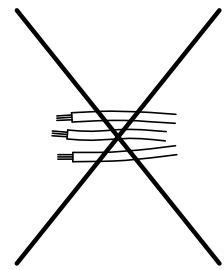
<p><b>OK</b></p> 	<p><b>NO</b></p> 	<p>Utilizzare solo cavi di alimentazione in doppia guaina. NON entrare con fili singoli.</p> <p>Usare solo cavi flessibili in gomma &lt;HAR&gt; di diametro adatto. NON USARE CAVI RIGIDI e/o CON ANIMA METALLICA (Cavi rigidi possono compromettere la tenuta IP65).</p> <p>Use only supply cables with double case. Do not enter with single cables.</p> <p>Use only &lt;HAR&gt; flexible cables of suitable diameter. DO NOT USE HARD CABLES OR ARMOURED CABLES (Hard cable could effect the IP65 protection).</p> <p>Brauchen Sie nur die Speisekabel mit doppeltem Mantel. Do not enter with single cables.</p> <p>Nur flexible Gummikabel &lt;HAR&gt; verwenden. KEINE STARREN LEITUNGEN VERWENDEN (diese können die Schutzart IP65 beeinträchtigen).</p>
----------------------------------------------------------------------------------------------------	----------------------------------------------------------------------------------------------------	-----------------------------------------------------------------------------------------------------------------------------------------------------------------------------------------------------------------------------------------------------------------------------------------------------------------------------------------------------------------------------------------------------------------------------------------------------------------------------------------------------------------------------------------------------------------------------------------------------------------------------------------------------------------------------------------------------------------------------------------------------------------------------

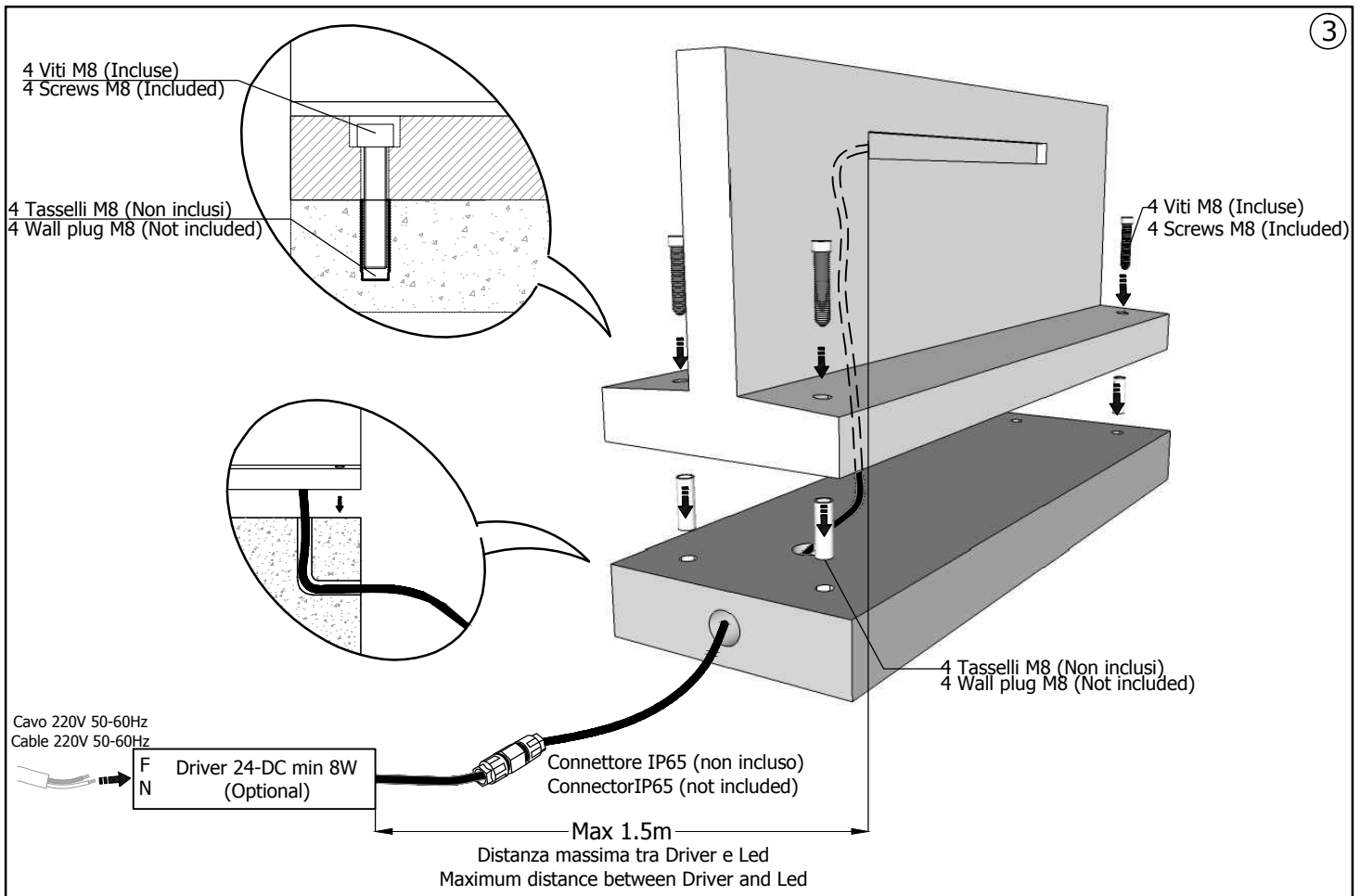
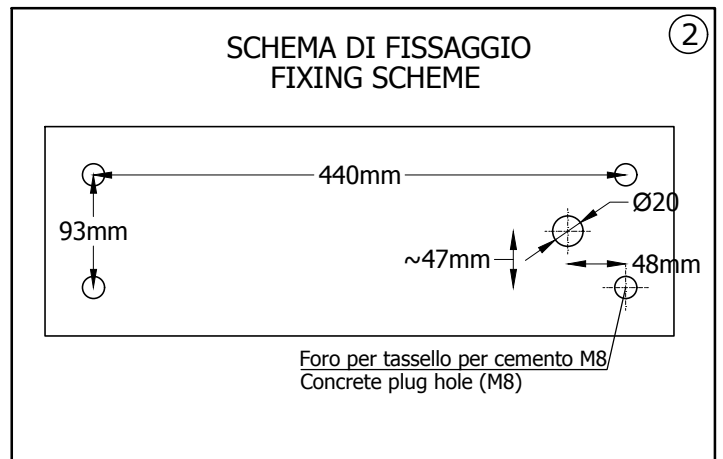
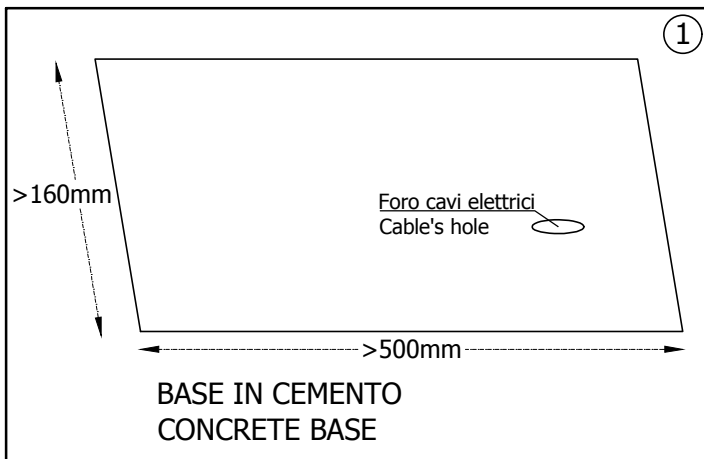

POSIZIONAMENTO UNDERSCORE SUL TERRENO  
PLACEMENT UNDERSCORE ON THE GROUND

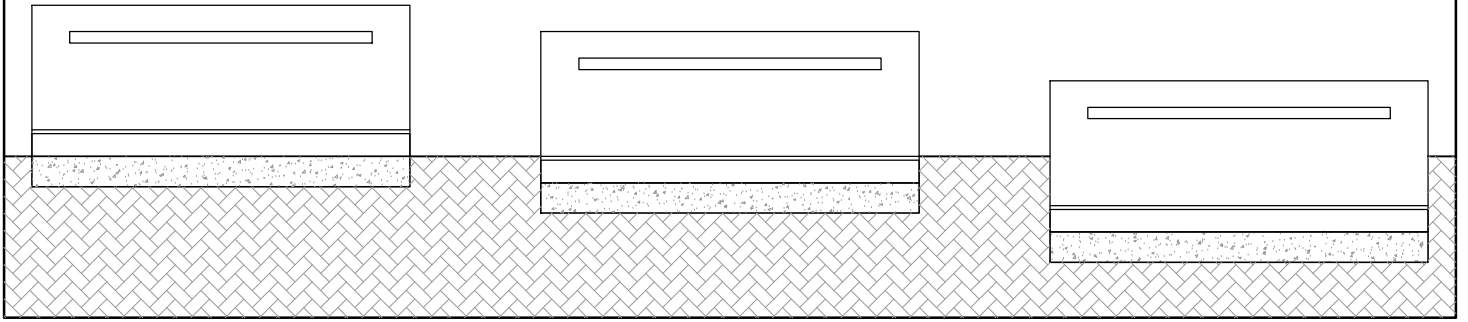

# **AVVERTENZE - WARNING - WARNUNG**

- Non utilizzare idropulitrici.
- Do not use water high pressure cleaners.
- Hochdruckreiniger benutzung ist verboten.

## **- OGNI MODIFICA DELL'APPARECCHIO É PROIBITA SENZA PREVIA AUTORIZZAZIONE!**

La sicurezza dell'apparecchio è garantita solo rispettando le normative europee del settore elettrico e le istruzioni contenute in questa scatola; pertanto è necessario conservarle. Il rispetto di queste istruzioni è fondamentale per il corretto funzionamento dell'apparecchio e dell'impianto. L'installazione deve essere fatta da personale qualificato. Togliere tensione prima di eseguire le operazioni di manutenzione. Gli apparecchi in CLASSE I devono essere collegati al circuito di terra dell'impianto elettrico.

## **- ANY MODIFICATION TO THIS FITTING IS FORBIDDEN WITHOUT AUTHORIZATION!**

The safety of the fitting is guaranteed only respecting the electrical European norms and the mounting instructions in this box; therefore it is important to conserve them. The respect of these instructions is very important for the fitting and the main line life. Installation should be carried out by a suitable qualified person in accordance with good electrical practice and the appropriate national wiring regulations. Disconnect main voltage before maintenance operations. The CLASS I fittings must be connected to the main earth circuit.

## **- JEDE UNBEFUGTE ÄNDERUNG AN DIESER LEUCHTE IST VERBOTEN!**

Die Sicherheit der Leuchte ist nur bei Einhaltung der europäischen Normen und der in dieser Packung enthaltenen Montageanleitungen gewährleistet. Diese sind daher sorgfältig aufzubewahren. Diese Anweisungen sind daher unbedingt einzuhalten, um die Funktionsfähigkeit dieser Leuchte und der Beleuchtungsanlage sicherzustellen. Bitte sorgfältig aufbewahren.

Diese Leuchte muss fachmännisch installiert werden.

Vor Wartungsarbeiten die Leuchte vom Netz trennen.

Die Leuchten mit der Schutzklasse I müssen an die Erdung der Anlage angeschlossen sein.